

RT20PH

RT Series Sit-on Reach Truck with capacity 2000kg Lifting height up to 12500mm

Safe and reliable:

- The tilting of the fork can effectively improve the stability of the whole vehicle and the loading capacity at height.
- The electro-hydraulic proportional control system has good fretting performance, more stable work and more precise control.
- Speed limit function, when the forklift lifts to a certain height, the driving speed of the forklift will automatically decrease to ensure the safety of high position operation.
- The height limit function, the lifting motor will automatically power off to ensure the safety of lifting when the forks lift to the maximum height.
- Turning speed limit control prevents the truck from tipping sideways when turning, ensuring the safety of the truck when turning.
- Smooth deceleration when the mast reaches/backwards to the end can ensure the stability of the mast movement.
- The motor temperature detection and control can effectively prevent the motor from being damaged due to excessive temperature.
- The motor current detection and control can effectively prevent the motor from being damaged due to excessive current.
- The combination of electromagnetic brake and hydraulic brake has a short braking distance, no deviation, no impact, and is safe and reliable.
- The parking electromagnetic brake can realize the one-key start operation function no matter it is on the slope or on the smooth ground.
- Using CAN bus communication technology, electrical wiring is simple, the compatibility is good, and the reliability is high.
- AC frequency conversion speed control technology enables stepless closed-loop speed control of driving, lifting, and steering drives, which is accurate and reliable.

Energy efficient:

- High-speed lifting and lowering control improves your work efficiency.
- It adopts AC drive motor, hydraulic pump motor and steering motor, with long service life, maintenance-free and reliable performance.
- Regenerative braking to achieve energy recovery and extend battery life.
- All lights use LED, durable and energy-saving.

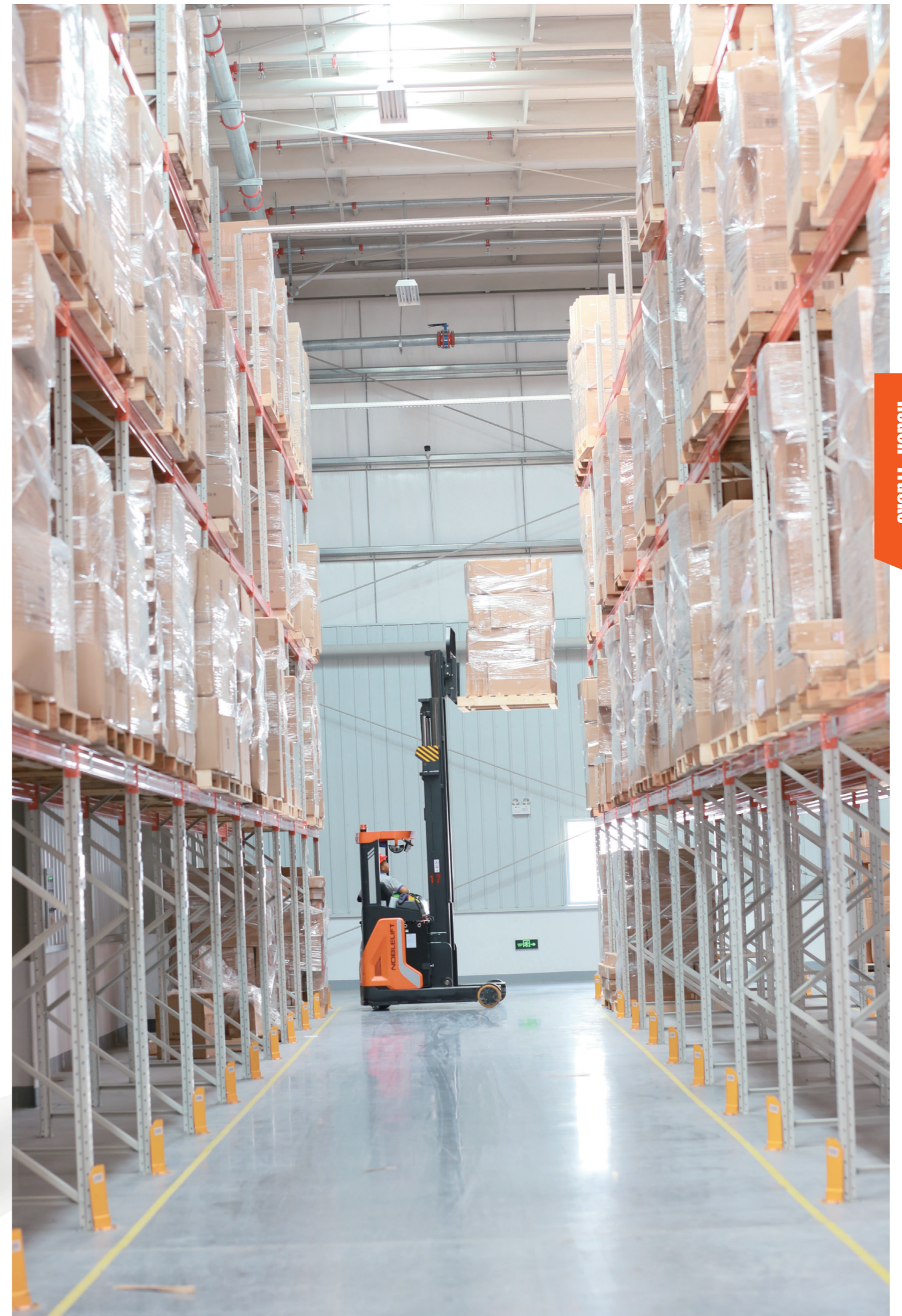
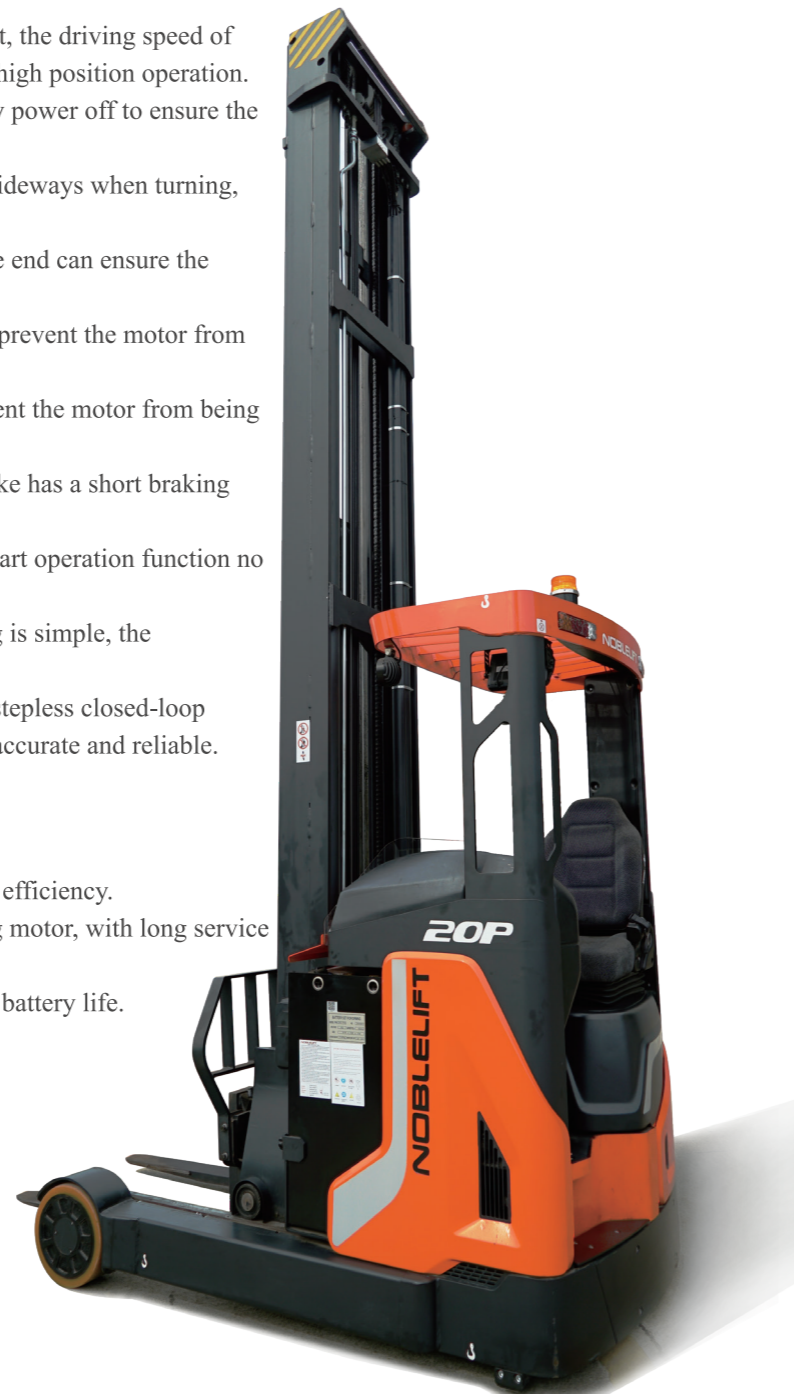

Model	Lift height h3 (mm)	Free lift h2 (mm)	Mast height h1 (mm)	Load capacity kg	Tilt of fork α/β (°)
20M1000	10000	3397	4067	900	4°/-2°
20M1050	10500	3563	4234	800	4°/-2°
20M1100	11000	3730	4400	700	4°/-2°
20M1150	11500	3897	4567	600	4°/-2°
20M1200	12000	4063	4733	550	4°/-2°
20M1250	12500	4230	4900	500	4°/-2°

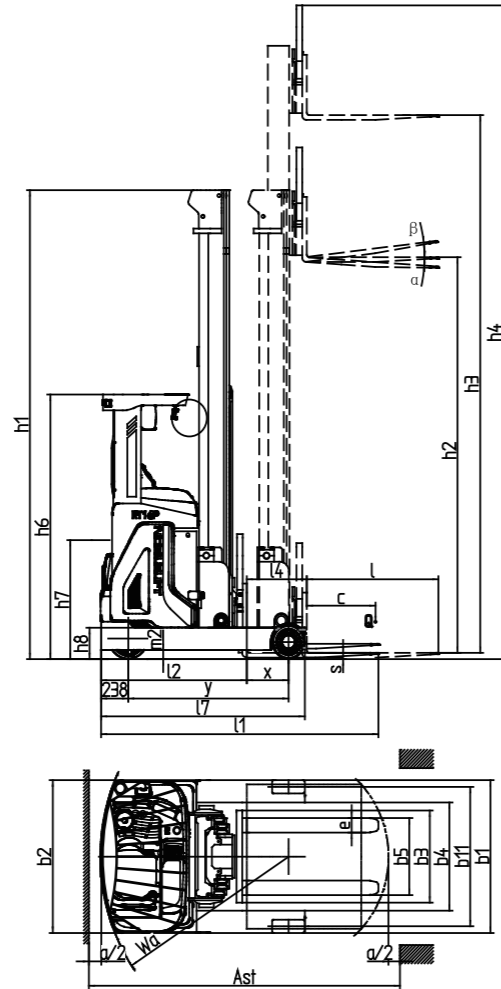
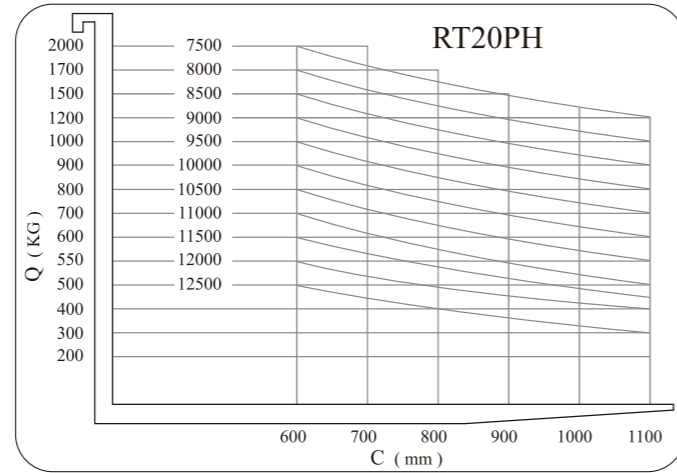

Type sheet for industrial truck acc. to VDI 2198 1KG=2.2LB 1INCH=25.4MM

Identification			
1.2	Manufacturer's type designation		RT20PH
1.3	Drive:electric(battery or mains),diesel,petrol gas,manual)		electric
1.4	Type of operation(hand,pedestrian,standing,seated,order-picker)		seated
1.5	Load capacity/rated load	Q(kg)	2000
1.6	Load centre distance	c(mm)	600
1.8	Load distance,centre of drive axle to fork	x(mm)	405/234
1.9	wheelbase	y(mm)	1590
Weights			
2.1	Service weight incl. battery	kg	5200
2.3	Axle load, mast retracted without load, drive/support arm wheel	kg	/
2.4	Axle load, mast extended with load, drive/support arm wheel	kg	/
2.5	Axle load, mast retracted with load, drive/support arm wheel	kg	/
Wheels- Chassis			
3.1	Type:solid rubber,supereelastic,pneumatic,polyurethane		pu
3.2	Tyres size,front	Øxw (mm)	Ø406×152
3.3	Tyres size,rear	Øxw (mm)	Ø330×140
3.5	Wheels,number front/rear(×=driven wheels)		1×2
3.7	Track width,rear	b11(mm)	1290
Basic Dimensions			
4.1	Mast/fork carriage tilt forward/backward	α/β (°)	4°/-2°
4.2	lowered mast height	h1(mm)	4900
4.3	Free lift	h2(mm)	4290
4.4	Lift height	h3(mm)	12500
4.5	Extended mast height	h4(mm)	13410
4.7	Overhead load guardheight	h6(mm)	2200
4.8	Seat height/standing height	h7(mm)	1100
4.10	Height of support arms	h8(mm)	270
4.15	Height of lowered forks	h13(mm)	40
4.19	Overall length	l1(mm)	2580
4.20	Length to face of forks	l2(mm)	1430
4.21	Overall width	b1/b2(mm)	1430/1270
4.22	Fork dimensions	s/e/l(mm)	40/120/1150
4.23	Fork carriage ISO 2328, class/type A, B		2A
4.25	Width across forks	b5(mm)	200-740
4.26	Distance between support arms	b4(mm)	1000
4.28	Reach distance	l4(mm)	640
4.31	Ground clearance ,laden,under mast	m1(mm)	90
4.32	Ground clearance,centre of wheelbase	m2(mm)	75
4.33	Aisle width for pallets 1000×1200 crossways	Ast(mm)	2880
4.34	Aisle width for pallets 800×1200 lengthways	Ast(mm)	2975
4.35	Turning radius	Wa(mm)	1840
4.37	Length across support arms	l7(mm)	2000
Performance Data			
5.1	Travel speed,laden/unladen	km/h	10/11
5.2	Lift speed,laden/unladen	m/s	0.35/ 0.5
5.3	lowering speed,laden/unladen	m/s	0.45/0.45
5.4	Reach speed, with/without load	m/s	0.1/0.1
5.8	Max. gradeability, with/without load	%	10/10
5.10	Service brake		Hydraulic/electric
E-Motor			
6.1	Drive motor rating S2 60 min	kW	7
6.2	Lift motor rating at S3 15%	kW	12.5
6.4	Battery voltage,nominal capacity K5	V/Ah	48/700
6.5	Battery weight	kg	1145(700Ah)
Other Details			
8.1	Type of drive control		AC
8.4	Sound level at driver's ear according to EN 12 053	dB(A)	68