

Man-up turret truck

OPK-160

Rated Load: 1600kg

Lifting height: 6500/14500 mm



High Performance



Robust Design



High-performance battery

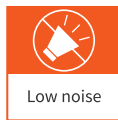

Low noise



Easy Maintenance



Highly Cost Effective



Efficient Operation

Why choose between price and quality **WHEN YOU CAN HAVE BOTH!**

Product Highlights

- ▶ Man-up operation mode: Stacking and picking, dual-purpose machine.
- ▶ Ultra-narrow aisle: Increases warehouse capacity and efficiency.
- ▶ 80V AC system: Stable and reliable operation; maintenance-free motor.
- ▶ CAN-BUS communication control.
- ▶ Gravitational potential energy recovery: extends battery operation time.
- ▶ Three driving speeds: Slow, medium, and fast, selectable according to different working conditions.
- ▶ Multi-level safety alarm system: Includes laser collision avoidance sensors, emergency braking, and audible and visual alarms to ensure personal and vehicle safety.
- ▶ Coordinated control of driving speed, lifting height, and load capacity: ensures dynamic stability at high positions.
- ▶ Foldable seat: allows for sitting or standing, facilitating operation.
- ▶ Fault diagnosis system: facilitates maintenance and repair.
- ▶ Excellent compatibility: suitable for AGV and other automation retrofits.



The OPK-160 Man-up turret truck is a high-performance, efficient, and stable expert-grade machine capable of efficiently completing pallet stacking and retrieval tasks, while also being suitable for single-item picking operations in high-rack environments. Whether in the mid-level lifting area or at an operating height of up to 16.28 meters, the OPK-160 can help you take your warehousing and logistics efficiency to a whole new level.

Flexible driving experience: Operable either seated or standing. The spacious cabin features an adjustable control panel, ample storage space, and a variety of equipment options, allowing for personalized configuration to suit your specific warehousing processes – truly a bespoke solution.

Compact chassis suitable for narrow aisles

High performance and high productivity

It can operate in extremely narrow aisles of 1.7 meters, with a lifting height of up to 16.28 meters. Available single button multi-purpose function, featuring mast lifting and dual functions of picking and stacking.

Travel speed, lifting height, and load capacity are controlled in a coordinated manner to ensure dynamic stability during high-level operations, enhancing operational safety.



Intelligent, safe, and reliable



Centralized center console and instrument panel



Foldable seat and adjustable center console



LED work lights and fan



Side-accessible battery (can be used on either side)

Rack Requirements

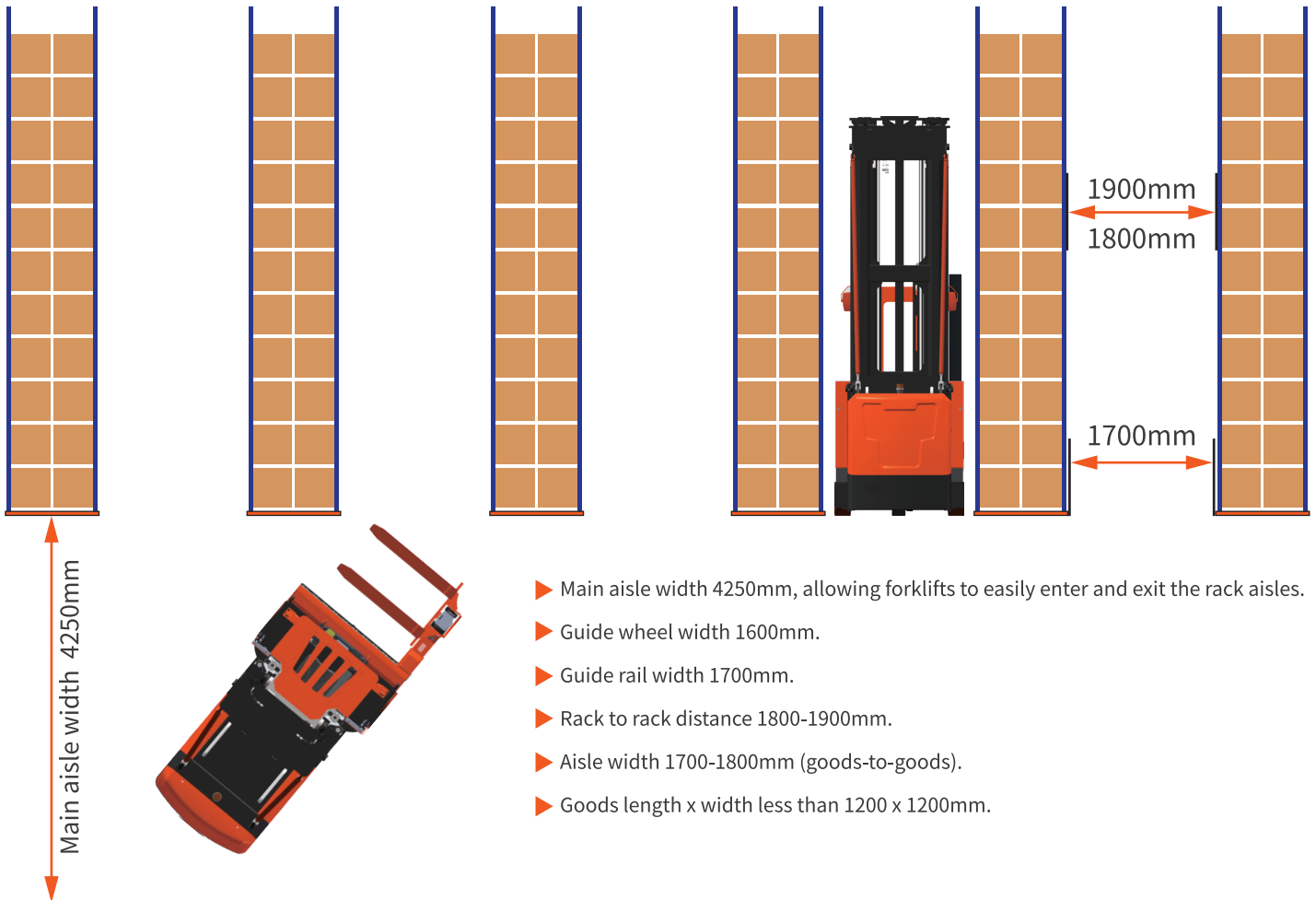

Magnetic strip/wire navigation (optional)

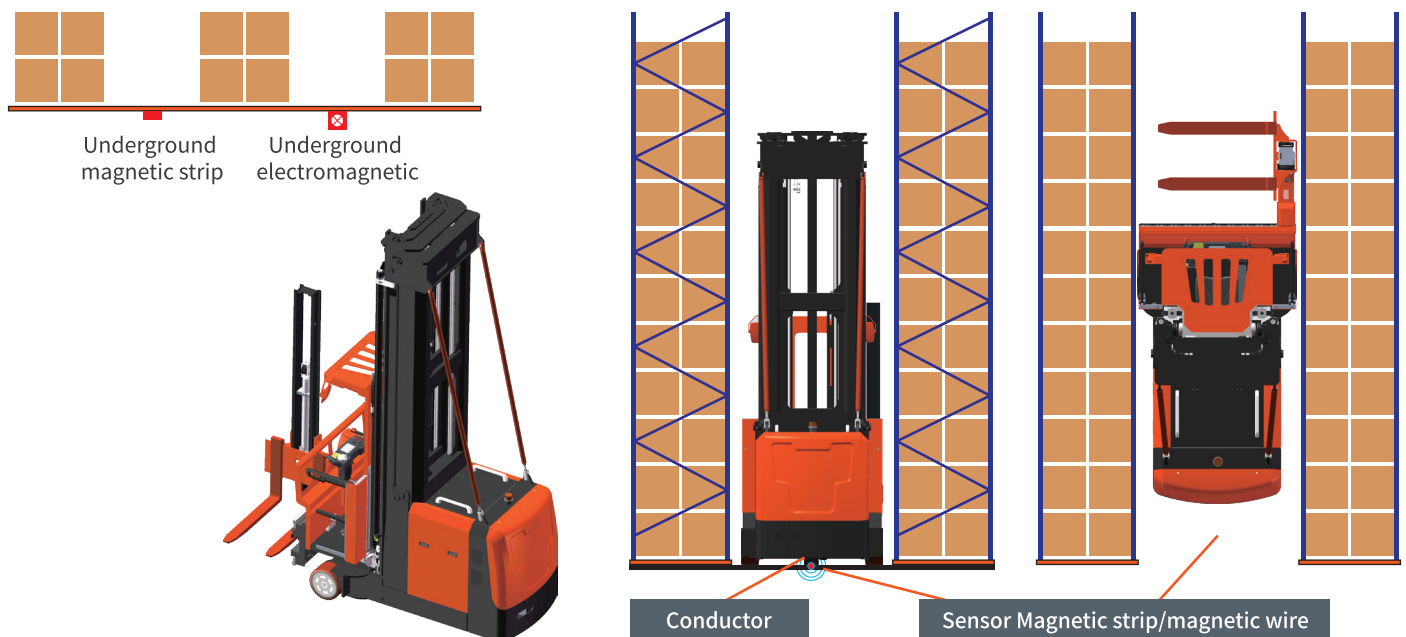

OPK-160 Man-up turret truck Configuration List

S.N.	Configuration	● standard ○ optional
1	AC Full-AC Power System	●
2	EPS Electronic Steering System	●
3	Electro-hydraulic Proportional Control System	●
4	80V High-Capacity Lead-Acid Battery	●
5	Central control instrument panel displays parking brake, driving direction, hour meter, driving speed, fault codes, etc	●
6	Eckerle low-noise gear pump	●
7	Gravitational potential energy recovery	●
8	180-degree fork rotation, 1.7-meter aisle width	●
9	German-made low-noise gearbox	●
10	Reversing camera system	○
11	Obstacle warning system	○
12	All-wheel electromagnetic braking system	●
13	Combined lateral and rotation operation	●
14	One-button centering	○
15	Foldable seats	●
16	Side-accessible battery	●
17	80V high-capacity lithium battery	○
18	Side guide wheels	●
19	Magnetic strip guidance within the passageway	○
20	Electromagnetic guidance within the passageway	○

Standard mast designs (mm) Two-stage mast ZT

Lift height (h3)	Total lift (h3+h9)	Stand height, elevated (h12)	Order picking height (h15)	Lowered mast height (h1)	Extended mast height (h4)
6000	7780	6430	8030	4205	8720
7000	8780	7430	9030	4805	9720
8000	9780	8430	10030	5305	10720
9000	10780	9430	11030	5905	11720
10000	11780	10430	12030	6405	12720
10500	12280	10930	12530	6655	13220

Standard mast designs (mm) Three-stage mast DT

Lift height (h3)	Total lift (h3+h9)	Stand height, elevated (h12)	Order picking height (h15)	Lowered mast height (h1)	Extended mast height (h4)
6500	8280	6930	8530	3495	9220
7500	9280	7930	9530	3895	10220
8500	10280	8930	10530	4295	11220
9500	11280	9930	11530	4695	12220
10500	12280	10930	12530	5045	13220
11500	13280	11930	13530	5395	14220
12500	14280	12930	14530	5750	15220
13500	15280	13930	15530	6250	16220
14500	16280	14930	16530	6850	17220

Structural Diagram/Load curve graph

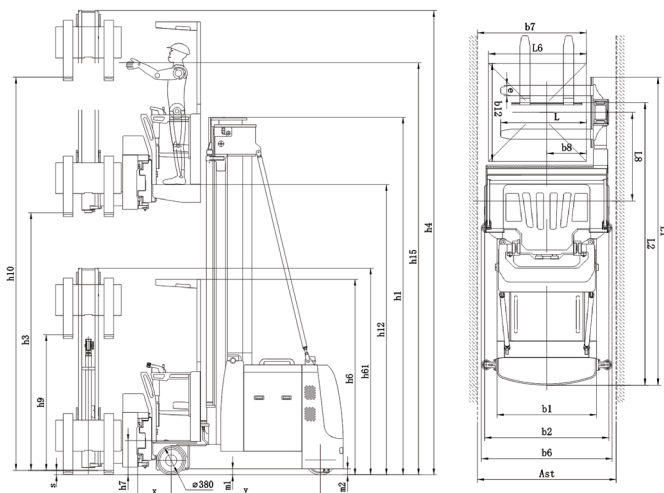

Dentification	1.1	Manufacturer (abbreviation)		NOBLELIFT
	1.2	Manufacturer' s type designation		OPK-160
	1.3	Drive (electric – battery or mains, diesel, petrol, fuel gas, manual)		Elektro
	1.4	Type of operation (hand, pedestrian, standing, seated, order picker)		tri-lateral stacker
	1.5	Load capacity / rated load	Q (kg)	1600
	1.6	Load centre distance	c (mm)	600
	1.8	Load distance, centre of drive axle to fork	x (mm)	1260
	1.9	Wheelbase	y (mm)	1950
	1.10	Contre drive wheel/Counter weight	z (mm)	280
	Weights	2.1	Service weight incl. battery (see line 6.5)	kg
2.2		Axle loading, laden front / rear	kg	8610/2270
2.3		Axle loading, unladen front / rear	kg	5515/3765
Wheels	3.1	Tyres (solid rubber, superelastic, pneumatic, polyurethane)		PU
	3.2	Tyre size, front	Øxw (mm)	380 x 192
	3.3	Tyre size, rear	Øxw (mm)	400 x 160
	3.5	Wheels, number front / rear (x = driven wheels)		2/1x
	3.6	Track width, front	b10 (mm)	1330
	Dimensions	4.2	Lowered mast height	h1 (mm)
4.3		Free lift	h2 (mm)	3760
4.4		Lift height	h3 (mm)	9500
4.5		Extended mast height	h4 (mm)	12220
4.7		Overhead load guard (cab) height	h6 (mm)	2550
4.8		Seat height / standing height	h7 (mm)	430
4.11		Additional lift	h9 (mm)	1780
4.14		Stand height, elevated	h12 (mm)	9930
4.19		Overall length (unladen)	l1 (mm)	3775
4.20		Length to face of forks	l2 (mm)	3465
4.21		Overall width	b1/b2 (mm)	1520
4.22		Fork dimensions	s/e/l (mm)	50 x125 x1200
4.23		Fork carriage ISO 2328, class / type A, B		2/B
4.24		Fork carriage width	b3 (mm)	860
4.25		Width over forks	b5 (mm)	820
4.27		Width across guide roller	b6 (mm)	1600
4.29		Reach, lateral	b7 (mm)	1320
4.30		Reach, lateral from vehicle centreline	b8 (mm)	486
4.31		Ground clearance, laden, under mast	m1 (mm)	75
4.32		Ground clearance, centre of wheelbase	m2 (mm)	75
4.33		Aisle width for pallets 1200 x 800	Ast(mm)	1700
4.35		Turning radius	Wa(mm)	2220
4.38		Distance to swivelling-fork pivot	l8(mm)	1050
4.39		Total lift	h3+h9(mm)	11280
4.40		Order picking height	h12 +1600(mm)	11530
4.41		Distance swivelling forks pivot point – steering rack	l8– x(mm)	610
4.42		Pallet width	b12(mm)	1200
4.43		Pallet length	l6(mm)	1200
4.44		Clear width driver compartment entrance	mm	420
4.45		Clear driver compartment height inside	mm	2100
4.46	Driver compartment width outside	b9(mm)	1490	
4.47	Width swivelling reach frame	b14(mm)	1494	
4.48	Width extension arm	l10(mm)	175	
4.49	Distance swivelling forks pivot point – fork carriage	r (mm)	170	
Performance data	5.1	Travel speed, laden / unladen	km/h	9
	5.2	Lift speed, laden / unladen	m/s	0.30/0.4
	5.3	Lowering speed, laden / unladen	m/s	0.19/0.32
	5.4	Reach speed, laden / unladen	m/s	0.2/0.2
	5.10	Service brake		reverse current / regenerative
	5.11	Parking brake		electric spring loaded / laminated
Electric motor	6.1	Drive motor rating S2 60 min.	kW	7.5
	6.2	Lift motor rating at S3 15%	kW	20
	6.3	Battery acc. to DIN 43531 /35 / 36 A, B, C, no		4PZS620
	6.4	Battery voltage, nominal capacity K5	V/Ah	80/620
	6.5	Battery weight	kg	1570
Other	8.1	Type of drive control		AC drive control
	8.4	Sound level at driver' s ear according to EN 12 053 dB (A)	dB(A)	70
	8.6	Steering		electric

A GLOBAL LEADER

NOBLELIFT CHINA

Address: 528 Changzhou Road, Taihu
Sub-district, Changxing, Zhejiang 313100 China
Tel: 86-572-6210817 6210311
Fax: 86-572-6210777 6128612
Email: info@noblelift.com
Http: www.noblelift.com www.noblelift.cn

NOBLELIFT NORTH AMERICA

Address: 2461 S Wolf Road Des Plaines, IL 60018
Tel: 001-847-595-7100
Fax: 001-847-595-7200
Email: sales@nobleliftna.com
Http: www.nobleliftna.com

NOBLELIFT SOUTH EAST ASIA

No. 7, Jalan Astaka U8/84A, Seksyen U8, Bukit Jelutong,
40150 Shah Alam, Selangor Darul Ehsan, Malaysia.
Tel: +603 7831 8555
Email: sales@nobleliftsea.com
https: www.nobleliftsea.com

NOBLELIFT SOUTH EAST ASIA (Vietnam) CO., LTD.

Address: 3rd floor, No. 107, Street 37, Van Phuc
Residential Area, Hiep Binh Phuoc Ward, Thu
Duc City, Ho Chi Minh City, Vietnam
Tel: 84-902 598 460
E-mail: marketingvn@nobleliftsea.com
www.nobleliftsea.com.vn

NOBLELIFT RUSSIA

ООО «Ноблелифт Рус», 195067, Санкт-Петербург
пр. Маршала Блюхера, д. 78, литер Б
Тел.: +7-800-700-28-97
Email: sales@noblelift.com.ru
Http: www.noblelift.com.ru

NOBLELIFT EUROPE

Industriepark 2, 48739 Legden, Germany
Tel: +49 2566 90902-0
Email: Mail@Noblelift-Germany.com
Http: www.Noblelift.com

NOBLELIFT KOREA CO., LTD.

Address: 715-9 Jubook-ri, Cheoin-gu, Yongin-si,
Kyunggi-do, Korea
Tel: 82-031 334 1828
E-mail: info@noblelift.com
www.noblelift.com

NOBLELIFT CANADA INC.

Address: 850, Ellingham Avenue, Pointe-Claire, province
of Québec, Canada, H9R 3S4
Tel: 1- 514 697 0117
E-mail: info@nobleliftca.com
www.nobleliftcanada.com

NOBLELIFT INTELLIGENT EQUIPMENT CO., LTD.



Official website



Our Wechat



LinkedIn



facebook



YouTube

